

SPINNER

U-1530 Compact

Universal Machining Centre



Mechanical Engineering

Made in Germany

www.spinner.eu.com
sales@spinner.eu.com

Machine Highlights

Available in 3 configurations

U3-1530 Compact: 3-axes-version with large fixed table

U4-1530 Compact: 4-axes-version with large rotary table and fixed table on left side in the working area

U5-1530 Compact: 5-axes-version with integrated rotary/tilting table and fixed table on left side in the working area

Compact

Top of machine fully closed

Tool magazine with up to 54 tools

High spindle speeds

Ergonomic operating panel adjustable in height

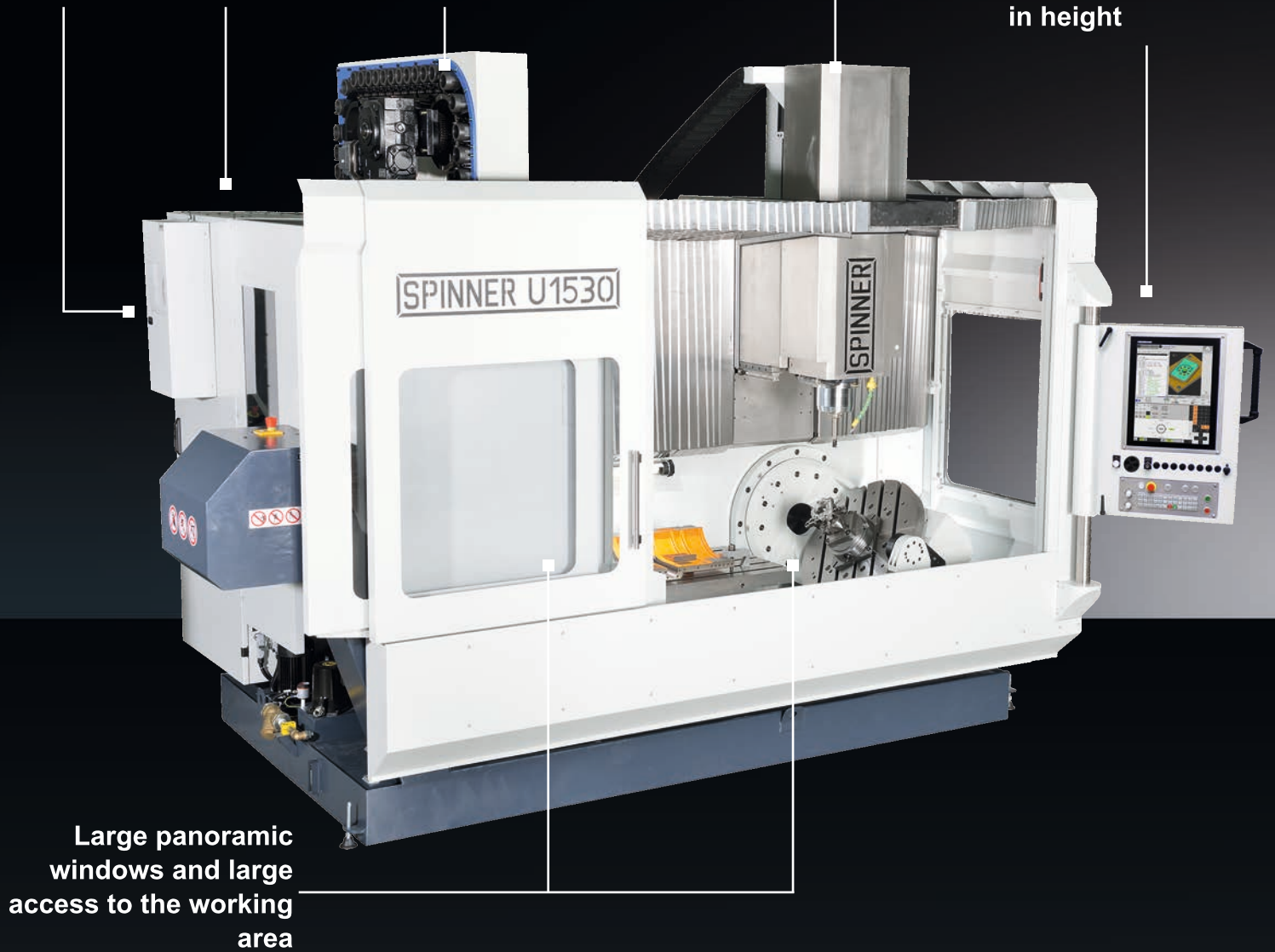

Large panoramic windows and large access to the working area

Heidenhain TNC620 Touchscreen

Siemens Sinumerik ONE Touchscreen

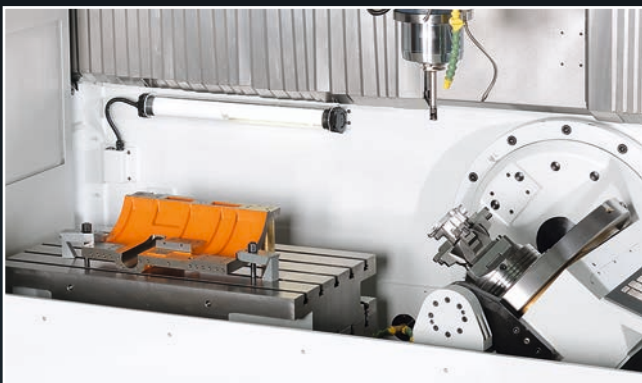

Ergonomic
Universal
Dynamic
Highly precise
Productive

5-axes simultaneous machining*

U3-1530 Compact [Fixed table]

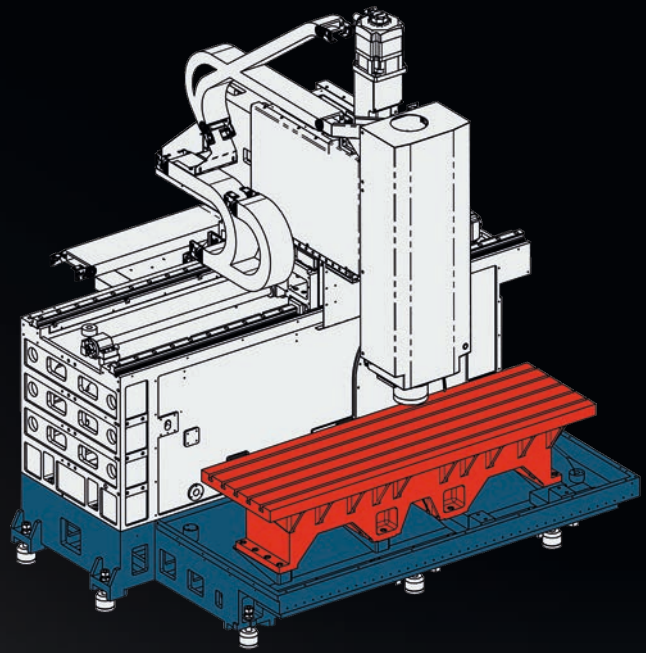

U5-1530 Compact [Rotary/Tilting table]

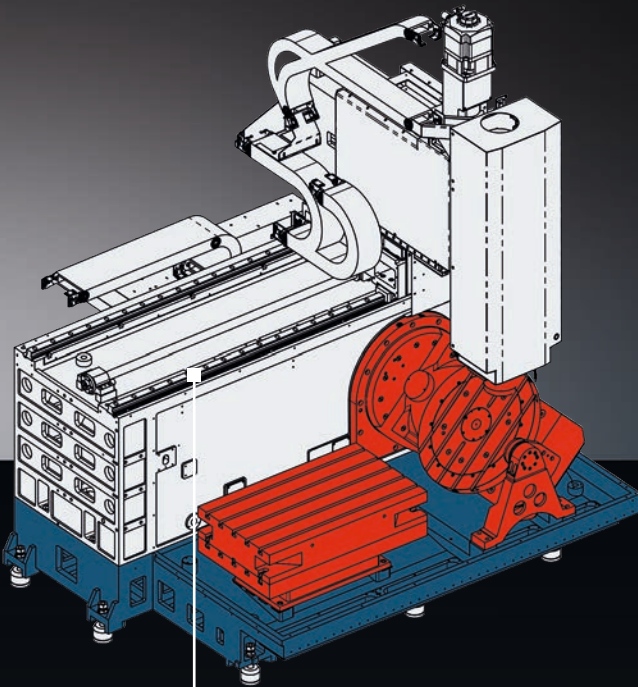

U4-1530 Compact [Rotary table]

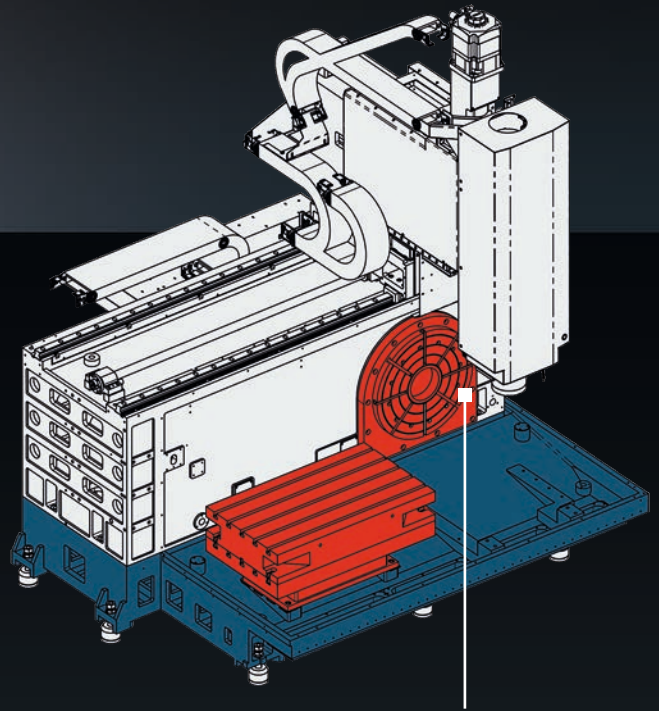

All versions with
modern linear
guides on rigid cast
construction



Clamping table U4-1530 Compact
Clamping surface on both sides

* Option

Working area	U3-1530 Compact	U4-1530 Compact	U5-1530 Compact
X axis	1530 mm (60.24")		
Y axis	530 mm (20.87")		
Z axis	465 mm (18.31")		
Table			
Table dimensions	1,800 x 540 mm (70.87" x 21.26")	410x610 mm (16.14"x24.01") ¹⁾ Ø 560 mm (22.04") ²⁾	Ø 650/500 mm (Ø 25.59"/19.69")
Max. table load	2,000 kg (4,409.25 lbs)	400 kg (881.85 lbs)	500 kg (1,102.31 lbs)
T-slots	18H8	14H8	18H8
Axes			
Feed / rapide traverse	X: 25 m/min (984.25 IPM); Y, Z: 30 m/min (1,181.10 IPM)		
Number of simultaneously interpolated axes	3 (4)	4	4 (5)
Spindle			
Max. speed	12,000 rpm (SK40)		
Performance P_{max}	13,3 kW		
Torque M_{max}	100 Nm		
Tool magazine			
Number of tool stations	24/32/54		
Max. tool diameter	76 mm (2.99")		
In case of free adjacent tool stations	130 mm (5.12")		
Max. tool length	300 mm (11.81")		
Max. tool weight	7 kg (15.43")		
General indications			
Dimensions (L x W x H) ³⁾	3,650 x 2,530 x 2,810 mm (143.70" x 99.60" x 110.63")		
Weight ⁴⁾	~ 10,500 kg (23,148.54 lbs) (according to the equipment)		

1) Clamping table, 2) Rotary table, 3) See floorplan, 4) Machine net weight

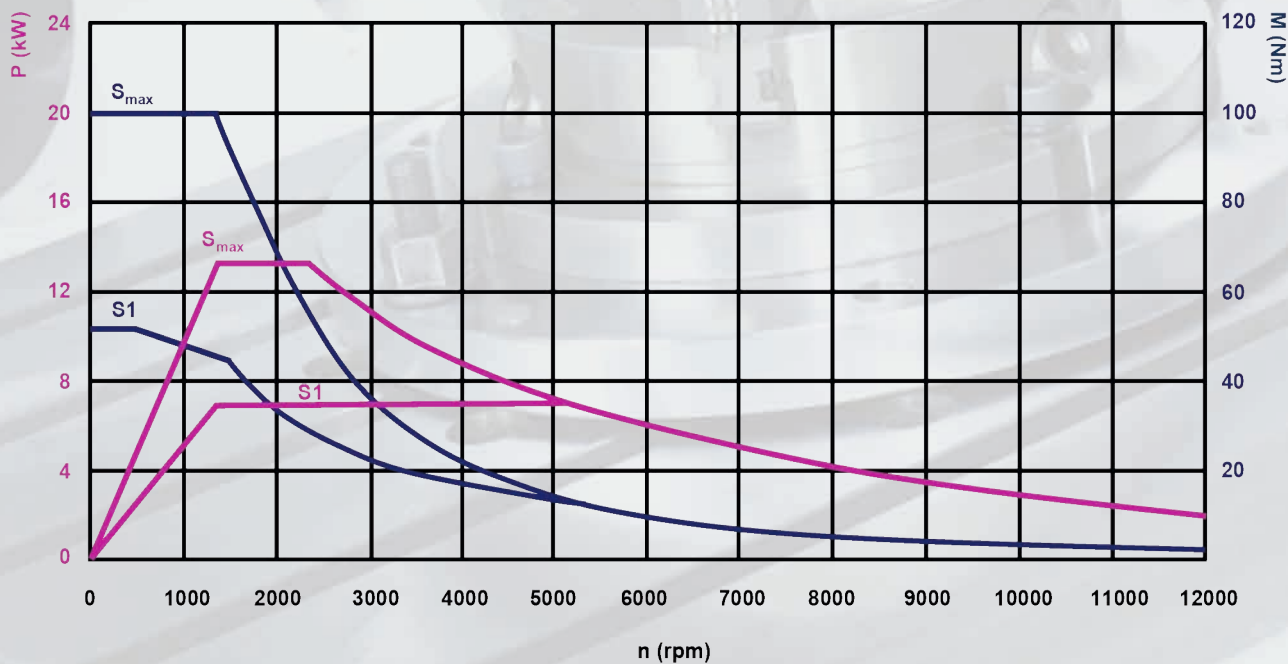

U3

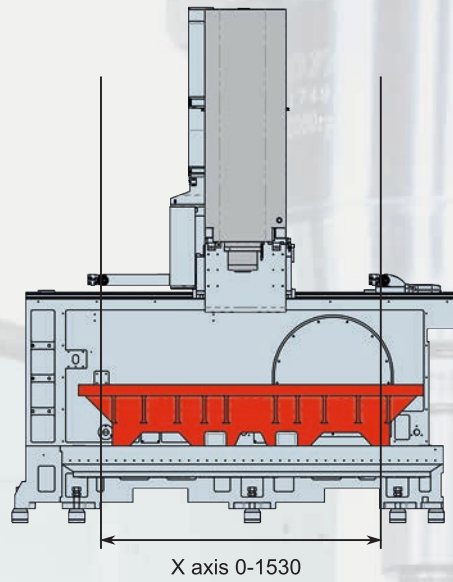
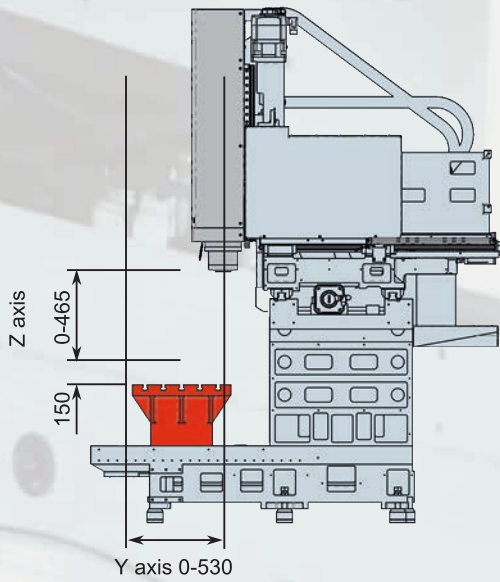

U4

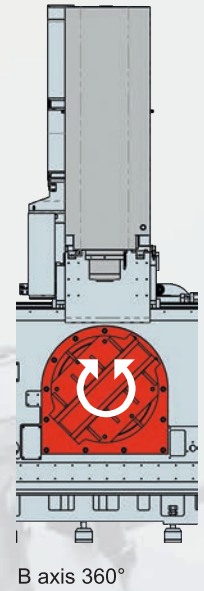
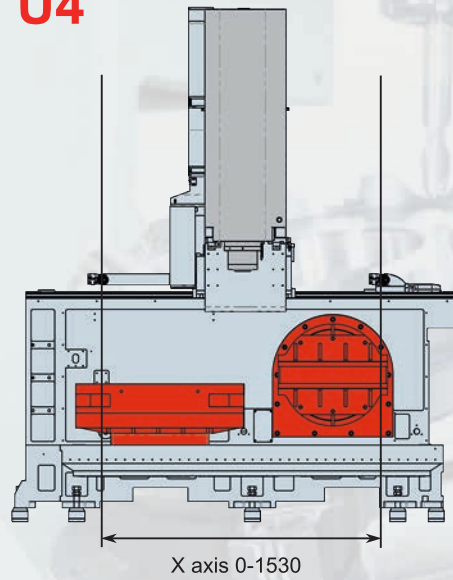
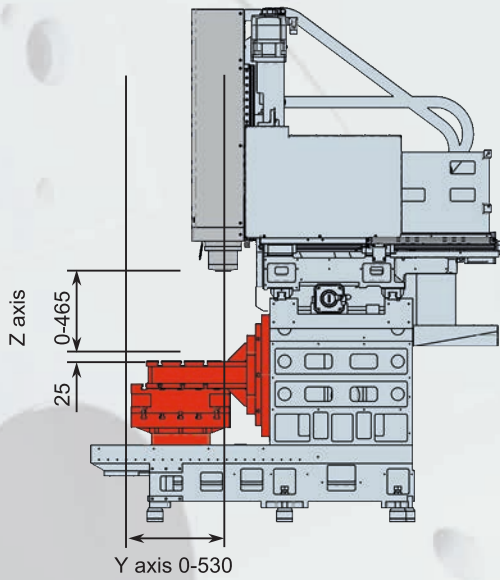

U5

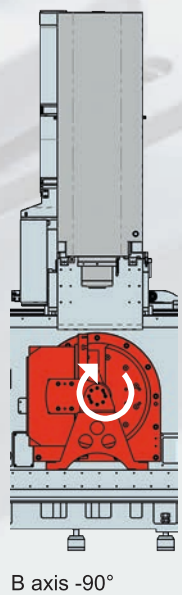
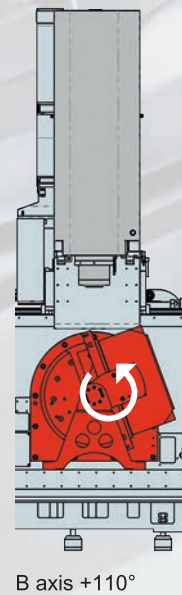
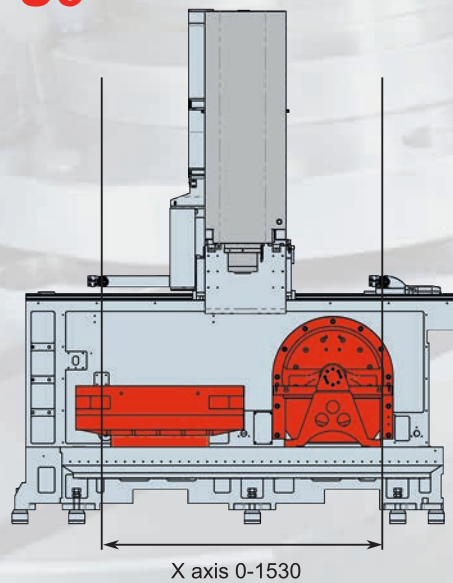
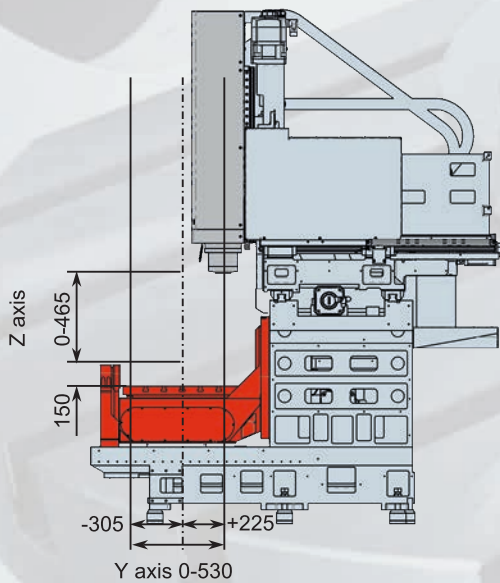

Magazine enlargement to 54 tools

Switching between coolant and blow air

Touchscreen: Siemens Sinumerik ONE or Heidenhain TNC620

Chip conveyor or chip box

High pressure coolant 22 bar through the spindle

Direct measuring systems

Coolant pistol in the working area

Removable table top for machining with tailstock

Clamping table for U4-1530 Compact

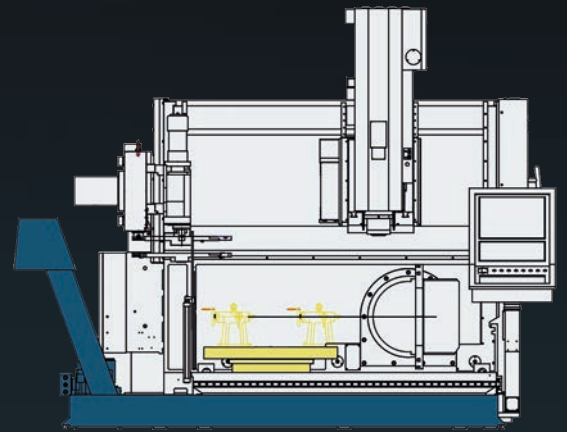

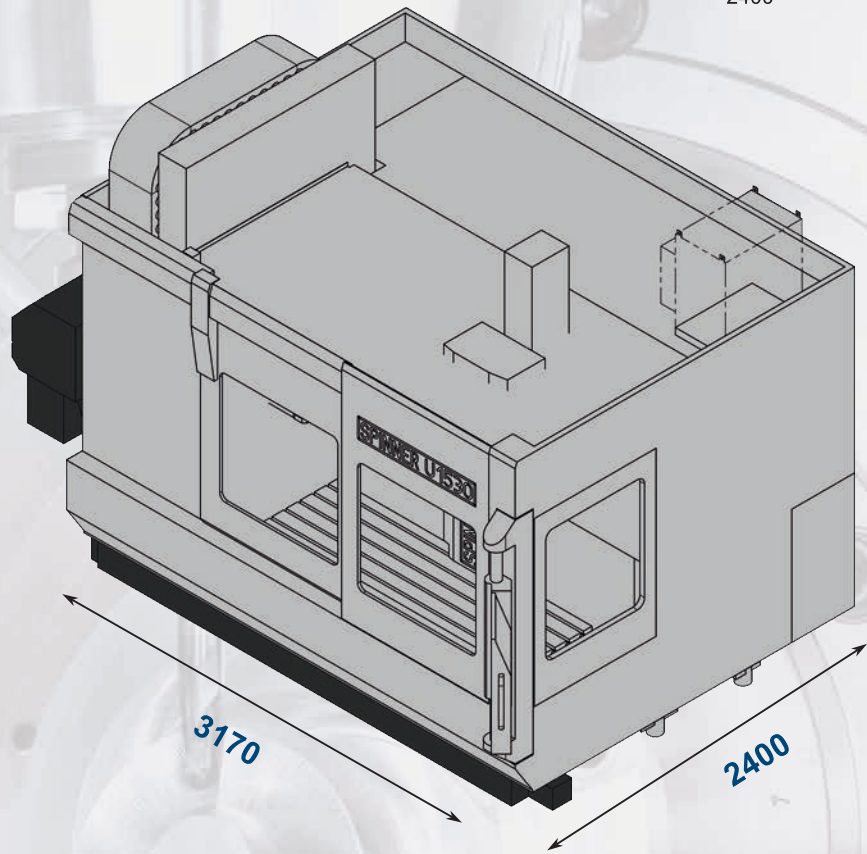
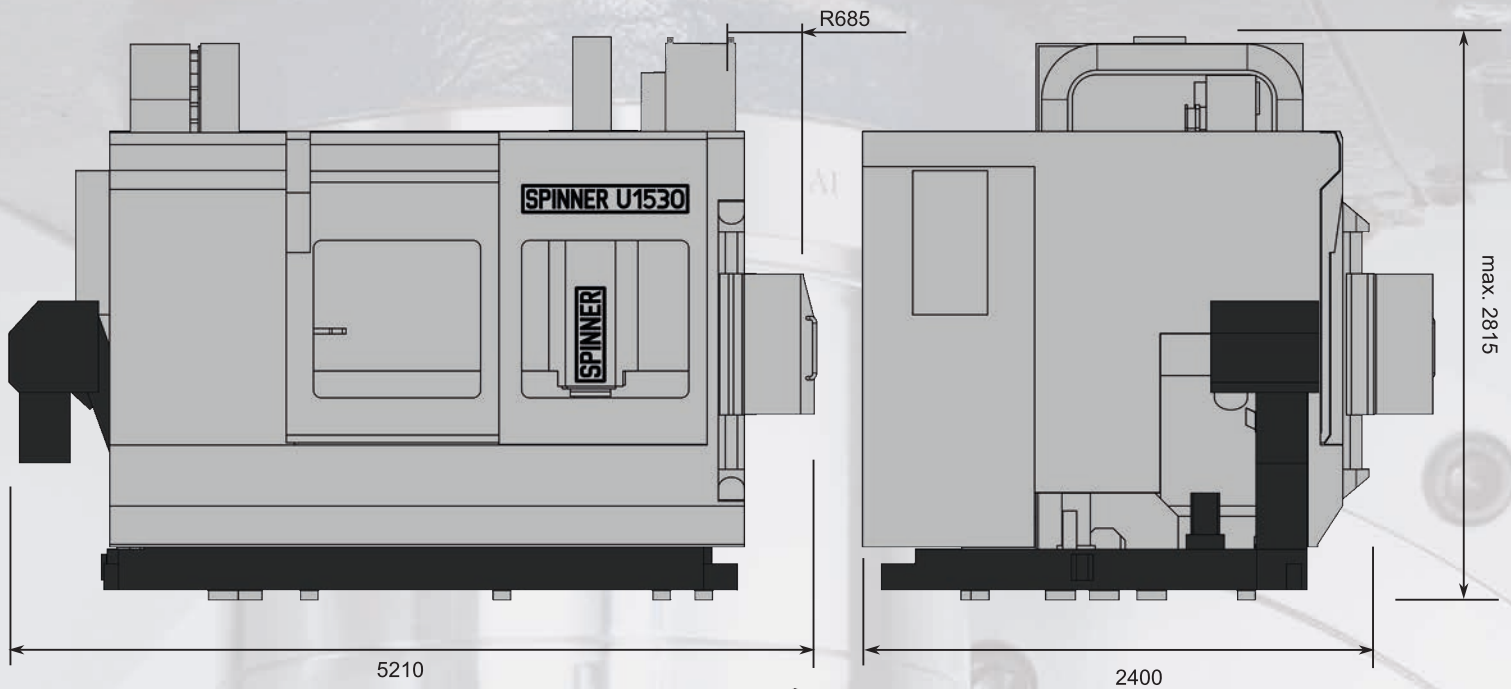

Compact dimensions for low space requirement

■ Version with standard chip conveyor



Werkzeugmaschinenfabrik GmbH



www.spinner.eu.com

Spinner Machine-Tools are working successfully world wide with many well known clients in more than 60 countries on 6 continents. We have been fortunate enough to attract small component suppliers in addition to well known global groups in all metal machining industries.

We have designed and produced the most modern machine-tools since 1950. More than 20.000 delivered machines demonstrate their high efficiency, precision and reliability, everyday.

Although Spinner is a medium-sized enterprise we produce and sell more than 1.000 CNC machines a year. And the number is increasing every year. Our company combines the know-how of a global player with the flexibility and cost-effective structures of a family owned business.

Place your trust in our products as well and let us know what we can do for you.



Video

SPINNER Werkzeugmaschinenfabrik GmbH

Rudolf-Diesel-Ring 24

82054 Sauerlach

Tel. +49 (0) 8104 803-0

Fax +49 (0) 8104 803-19

sales@spinner.eu.com



Version 8.5.2023 (GB)

Technical changes of specifications and pictures are subject to change without notice - Pictures can include options, accessories